

< With accessory >

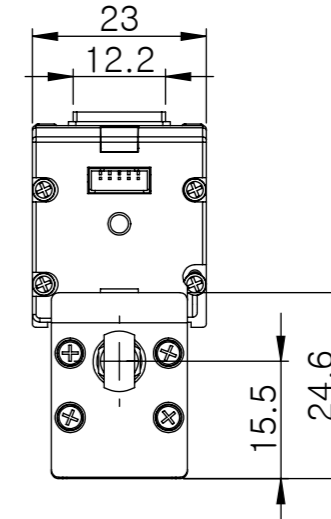
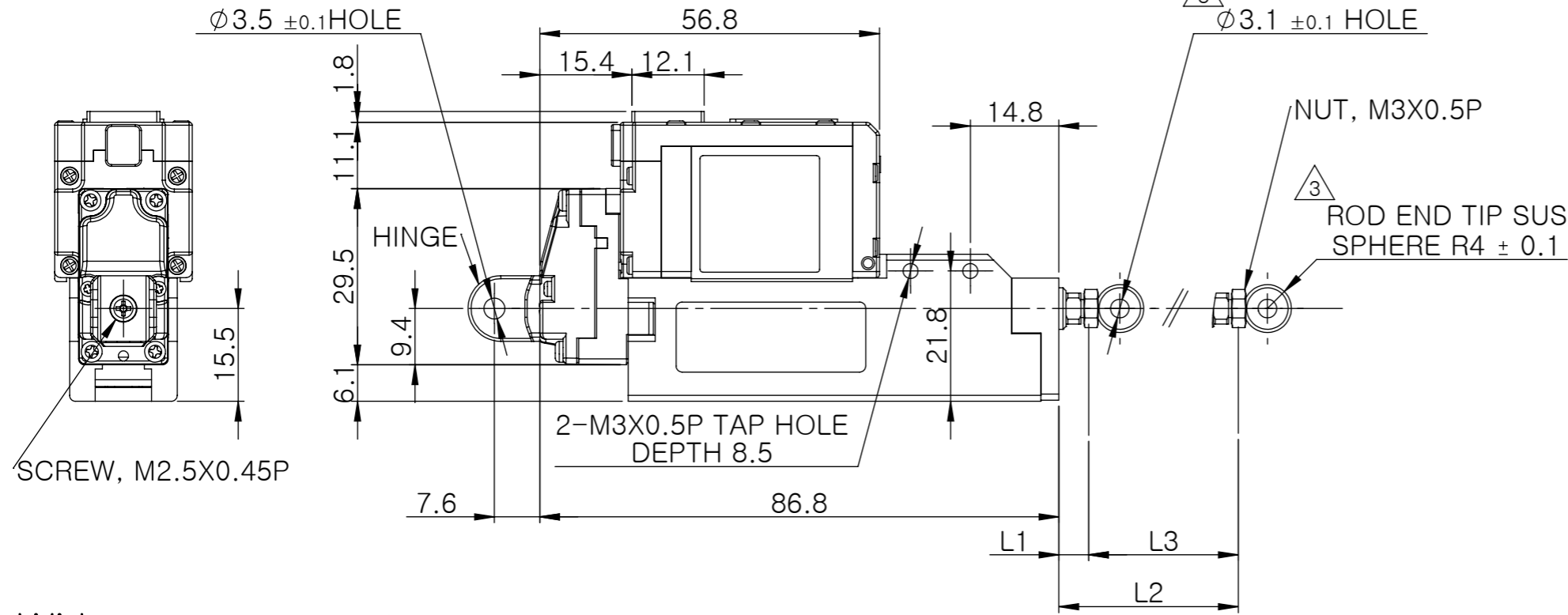
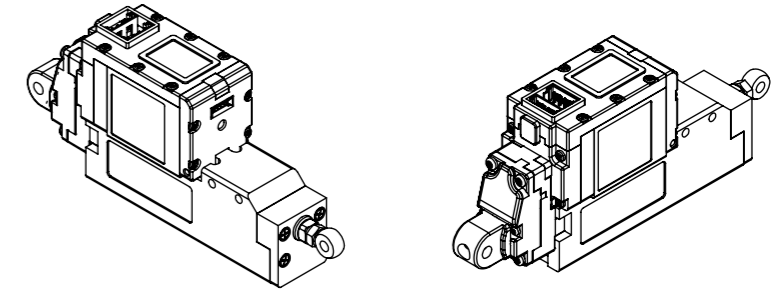
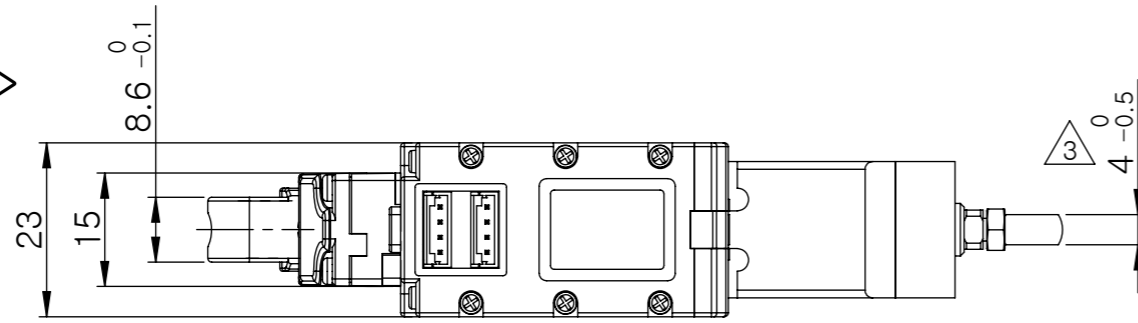

[UNIT: mm]

INDEX	DIMENSION
L1 (MIN POSITION)	5 ± 0.5
L2 (MAX POSITION)	42 ± 0.5
L3 (STROKE)	37 (=L2-L1)

< Without accessory >

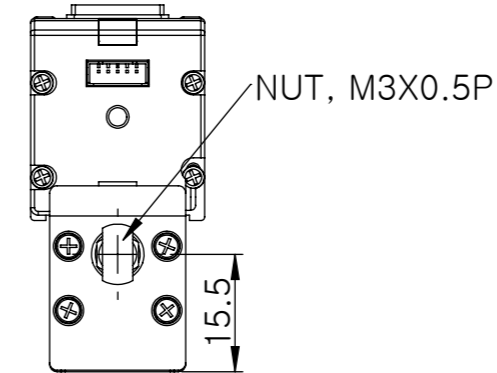
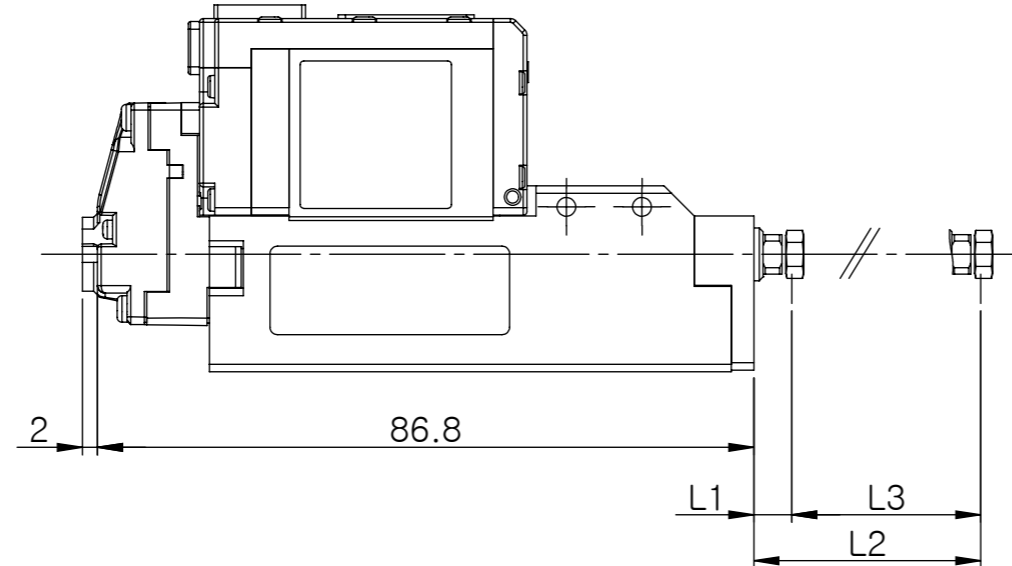
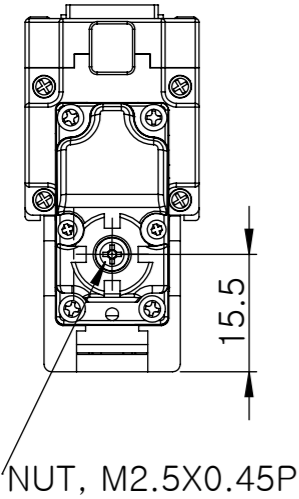

NOTE#1:
WEIGHT : 116.7 gf (with accessory)
113.5 gf (without accessory)

NOTE#2:

- ACCESSORY PART : SCREW M2.5X0.45P, HINGE, NUT M2.5X0.45P, NUT M3X0.5P, ROD END TIP SUS.
- ACCESSORY IS THE PARTS TO CONNECTE TO THE FIXTURE.
- UNSPECIFIED TOLERANCES ARE +/-0.2MM.

2	NA	ROD END TIP CHANGE TO ROD END TIP SUS	YC KIM	2025.05.23
1	NA	INITIAL RELEASE	YC KIM	2023.12.19
REV NO.	ECO NO	DESCRIPTION	DRAWN	DATE

MATERIAL: NA

PROCESS: NA

COLOUR: BLACK & STEEL

DRAWN YC KIM
CHK'D
APPV'D

SIGNATURE
DATE 2023.12.19

VOLUME [mm³]:
WEIGHT [gf]:
See Note #1

• DO NOT SCALE DRAWING.
• IF IN DOUBT, ASK.
• ALL DIMENSIONS IN mm.



IR ROBOT

(Private and Confidential)
Copyright ©2013

PART NAME: 17Lf-xxF-37
Servo series[mm]

PART NO: IRMAA0185~187
REV NO: 02

SCALE 2:1 SHEET 2 OF 2 A3